

# **SOUTHWORTH**

## **OWNER'S MANUAL**

### PalletPal™ Stretch Wrapper

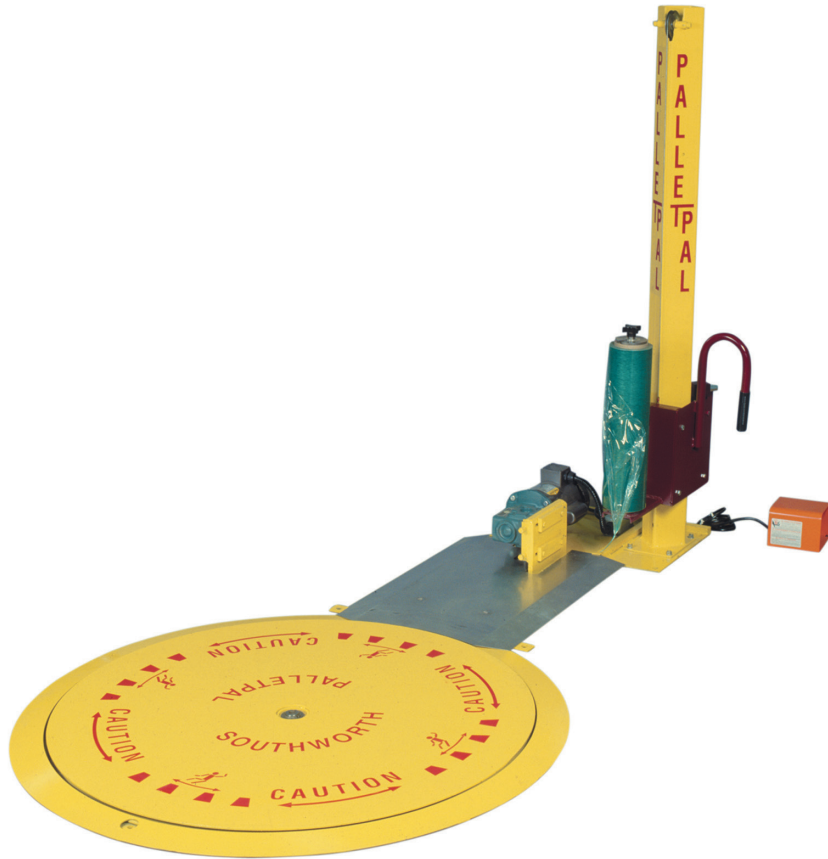

Model # \_\_\_\_\_

Serial # \_\_\_\_\_

Placed in Service \_\_\_\_\_

**SOUTHWORTH PRODUCTS**

distributed by



844 220 0086 [www.tceconveyors.com](http://www.tceconveyors.com)

Thomas Conveyor & Equipment  
15450 Summit Ave #175  
Oakbrook Terrace IL 60181

MAY 2016

Please note: This manual was current at the time of printing.  
To obtain the latest, most updated version, please contact  
Southworth's Customer Service Department or go to our website:  
[www.SouthworthProducts.com](http://www.SouthworthProducts.com)  
Go to Parts & Service and select Online Manuals,  
you will find a complete list of current owner's manuals to print.

**TABLE OF CONTENTS**

INTRODUCTION ..... 4

RESPONSIBILITY OF OWNERS AND USERS .....5

SAFETY ALERT SYMBOLS AND SIGNAL WORDS.....6

SAFETY .....7

IMPORTANT INSTALLATION NOTES .....7

    Specifications .....8

    Unpacking the Lift .....8

    Assembly.....9

    Anchoring the Unit .....9

    Electric Connections .....10

    Testing .....10

OPERATING INSTRUCTIONS .....10

    Loading Film .....10

    Wrapping Film.....10

    Stopping the Machine.....11

    Operation Notes .....11

    Safety Labels .....12

    Labels .....13

MAINTENANCE .....14

    Routine Periodic Maintenance .....14

    Adjusting the Belt Tension .....14

    Removing the Turntable .....14

    Inspecting and Lubricating the Turntable.....15

    Changing the Drive Belt.....15

    Troubleshooting Check List .....16

ORDERING REPLACEMENT PARTS .....17

WARRANTY STATEMENT .....20

**LIST OF FIGURES**

Figure 1: PalletPal Stretch Wrapper .....8

Figure 3: Wiring Diagram.....18

## INTRODUCTION

The PalletPal™ Stretch Wrapper is an industrial grade powered turntable stretch wrapper. The unit improves productivity and reduces worker fatigue and injury. It also produces tighter, more secure wraps. The PalletPal™ Stretch Wrapper unit saves film, and uses less expensive film than hand wrappers.

This manual contains information to help you to learn about the safe and proper installation, use and upkeep of your PalletPal™ Stretch Wrapper. Please be sure that this manual is available to anyone who uses or services the stretch wrapper. Be sure that everyone who uses the stretch wrapper has read this manual.

The PalletPal™ Stretch Wrapper units may be used in a wide variety of industrial settings. The instructions included in this manual are not necessarily all-inclusive, because Southworth cannot anticipate all conceivable or unique situations.

In the interest of safety, please read this whole manual carefully. Please understand the material in the manual before you install, use, or service the Stretch Wrapper unit. If you have any questions about the instructions in this manual, please contact your dealer or Southworth Products Corp.

Southworth's product warranty is shown on the rear cover of this manual. This instruction manual is not intended to be or to create any other warranty, express or implied, including any implied warranty of merchantability or fitness for a particular purpose, all of which are hereby expressly excluded.

As set forth more specifically in the product warranty, Southworth's obligation under that warranty is limited to the repair or replacement of defective components, which shall be the buyer's sole remedy, and Southworth shall not be liable for any loss, injury, or damage to persons or property, nor for any direct, indirect, or consequential damage of any kind resulting from the PalletPal™ Stretch Wrapper unit.

## **Responsibility of Owners and Users**

### **Inspection and Maintenance**

The device shall be inspected and maintained in proper working order in accordance with Southworth's owner's manual.

### **Removal from Service**

Any device not in safe operating condition such as, but not limited to, excessive leakage, missing rollers, pins, or fasteners, any bent or cracked structural members, cut or frayed electric, hydraulic, or pneumatic lines, damaged or malfunctioning controls or safety devices, etc. shall be removed from service until it is repaired to the original manufacturer's standards.

### **Deflection**

It is the responsibility of the user/purchaser to advise the manufacturer where deflection may be critical to the application.

### **Repairs**

All repairs shall be made by qualified personnel in conformance with Southworth's instructions.

### **Operators**

Only trained personnel and authorized personnel shall be permitted to operate the lift.

### **Before Operation**

Before using the device, the operator shall have:

- Read and/or had explained, and understood, the manufacturer's operating instructions and safety rules.
- Inspected the device for proper operation and condition. Any suspect item shall be carefully examined and a determination made by a qualified person as to whether it constitutes a hazard. All items not in conformance with Southworth's specification shall be corrected before further use of the equipment.

### **During Operation**

The device shall only be used in accordance with this owner's manual.

- Do not overload.
- Ensure that all safety devices are operational and in place.

### **Modifications or Alterations**

Modifications or alterations to any Southworth industrial positioning equipment shall be made only with written permission from Southworth.

# SAFETY ALERT SYMBOLS AND SIGNAL WORDS

The safety of all persons operating, maintaining, repairing, or in the vicinity of this equipment is of paramount concern. This is a powerful machine with moving parts, and is capable of causing personal injury if proper precautions are not taken. Therefore, throughout this manual, certain hazards have been identified which may occur in the use of the machine, and there are appropriate instructions or precautions which should be taken to avoid these hazards. In some cases, there are consequences which may occur if instructions or precautions are not followed. Below are the symbols and signal words along with their definitions referenced from ANSI Z535.4 - Product Safety Signs and Labels.

## Safety Alert Symbols

These are the safety alert symbols. They are used to alert you to potential physical injury hazards. Obey all safety messages that follow this symbol to avoid possible injury or death.



For use with **DANGER** signal word  
(Red Background)



For use with **WARNING** signal word  
(Orange Background)



For use with **CAUTION** signal word  
(Yellow Background)

## Signal Words

The meaning of different signal words as defined by ANSI Standard Z535.4 indicates the relative seriousness of the hazardous situation.



(Red Background)

**DANGER** indicates a hazardous situation which, if not avoided, will result in death or serious injury.



(Orange Background)

**WARNING** indicates a hazardous situation which, if not avoided, could result in death or serious injury.



(Yellow Background)

**CAUTION**, used with the safety alert symbol, indicates a hazardous situation which, if not avoided, could result in minor or moderate injury.



(Blue Background)

**NOTICE** is used to address practices not related to personal injury.



(Green Background)

**SAFETY INSTRUCTIONS** (or equivalent) signs indicate safety-related instructions or procedures.

## SAFETY

The Stretch Wrapper unit has been carefully designed to be as safe as possible for operators and service workers. If you take a few common sense precautions, you will be able to use the machine safely. However, the Stretch Wrapper unit is a powerful machine with moving parts, and is capable of causing personal injury if proper precautions are not taken.

Therefore, throughout this manual, Southworth has identified certain hazards, which may occur in the use and servicing of the Stretch Wrapper unit, and has provided appropriate instructions or precautions, which should be taken to avoid these hazards. In some cases, Southworth has also pointed out the consequences which may occur if Southworth's instructions or precautions are not followed. Southworth uses the following system of identifying the severity of the hazards associated with its products:

### **⚠ DANGER**

Immediate hazard which will result in severe personal injury or death.

### **⚠ WARNING**

Hazard or unsafe practice which could result in severe personal injury or death.

### **⚠ CAUTION**

Hazard or unsafe practices, which could result in minor personal injury or property damage.

**Please read and follow this instruction manual, including all safety instructions and precautions, carefully and completely.**

## IMPORTANT INSTALLATION NOTES

### **⚠ DANGER**

The electric motor used in the unit can create sparks. Don't use the unit in an area where flammable gases may be present.

### **⚠ WARNING**

The unit is attached to the skid using metal bands. These bands are under high tension. The edges are sharp. Wear safety glasses and gloves when you handle or cut the banding.

### **⚠ WARNING**

Do not use the machine without tightening the bolts, which hold the tower and film carriage assembly. See Fig. 1. If you do not do this, the tower may fall when you try to raise the film carriage. You may be injured, or the machine may be damaged.

### **⚠ CAUTION**

When removing the unit from the shipping pallet, be very careful to support the section of the machine where the drive belt housing meets the turntable disk. This is the weakest point, yet it is very important to the function of the machine.

### **⚠ CAUTION**

During installation, do not tilt the unit more than 30 degrees or drop it. This can cause the balls in the carrier plate to become unseated. The machine may be damaged when you start the unit.

### **⚠ CAUTION**

The unit must be installed on a smooth flat surface. If the floor is not flat, this can create stresses in the base of the machine. The machine may not work properly, or parts of the machine may wear more quickly than they should.

### **⚠ CAUTION**

Do not use the machine unless it has been firmly anchored to the floor. If you do not do this, the machine may move as it operates. This can create stresses, which may damage the machine.

### **⚠ CAUTION**

Be sure the film carriage is latched in position at the bottom of the tower before you remove the tower from the pallet. If you do not do this, the carriage may slide as you remove the pallet.

### **⚠ CAUTION**

Do not move the machine once you have attached the tower. If you must move the machine, disassemble the tower first. If you strike the tower while moving the machine, it is very easy to damage the machine.

## INSTALLATION INSTRUCTIONS

### SPECIFICATIONS

**Load capacity:** 2500 lbs. uniform load

**Load size:** 50" wide x 50" long x 65" high

**Power:** 115V AC, 10, 60Hz, 6 amp

**Film capacity:** 10" dia. x 12"  
to 20" long 90-1/2" long

**Length overall:** 90-1/2"

**Height of mast:** 60-3/8"

**Height  
(film carriage  
raised, 20" film):** 66-3/4"

**Turntable ramp dia:** 49-7/16"

**Turntable  
diameter:** 43 3/8"

**Turntable height:** 1"

**Speed:** 8.25 rpm

**Controls:** Footswitch, momentary contact

**Net weight:** Approximately 600 lbs.

### Unpacking the Lift

The PalletPal Stretch Wrapper unit has been pre-wired and pre-assembled. It was tested to factory specifications before shipment.

1. Before you start to install the unit, check for local codes and ordinances, which may apply. It is your responsibility to obtain any necessary permits.
2. Please read all of these instructions carefully. Be sure to read and understand all of the warnings.
3. Inspect the shipping crate carefully for any damage that may have affected the machine. If you see signs of damage, tell the trucker. Also make a note of this on the shipping papers which you are asked to sign.
4. Choose the place where you want to mount the unit. It is extremely important that the PalletPal Stretch Wrapper be set up on a smooth and flat surface. Check the floor surface carefully and make sure that it is free of all loose debris and dirt.

#### **⚠ DANGER**

The electric motor used in the unit can create sparks. Don't use the unit in an area where flammable gases may be present.

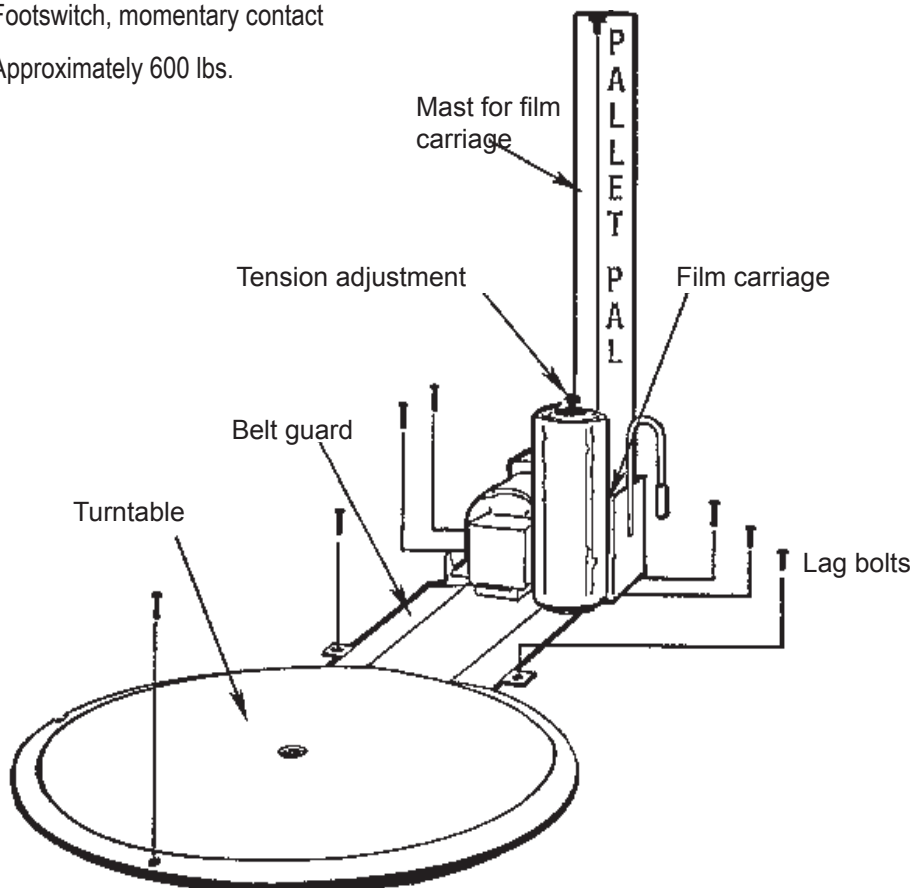



- Position the crate beside the point where the machine will be set up.

**⚠ WARNING**

The unit is attached to the skid using metal bands. These bands are under high tension. The edges are sharp. Wear safety glasses and gloves when you handle or cut the banding.

- Remove the metal banding which secures the machine to the pallet. Remove all packing material.
- Remove the tower and set it aside.

**⚠ CAUTION**

Be sure the film carriage is latched in position at the bottom of the tower before you remove the tower from the pallet. If you do not do this, the carriage may slide as you remove the pallet.

- Carefully remove the turntable assembly and place it in the center of the setup area. Slide the disk and drive belt assembly onto the floor. The best way to do this is to make a ramp to the floor, using steel or wood lengths. Slowly slide the disk and drive belt to the floor using this ramp.

**⚠ CAUTION**

When removing the unit from the shipping pallet, be very careful to support the section of the machine where the drive belt housing meets the turntable disk. This is the weakest point, yet it is very important to the function of the machine.

**⚠ CAUTION**

During installation, do not tilt the unit more than 30 degrees or drop it. This can cause the balls in the carrier plate to become unseated. The machine may be damaged when you start the unit.

**⚠ CAUTION**

The unit must be installed on a smooth flat surface. If the floor is not flat, this can create stresses in the base of the machine. The machine may not work properly, or parts of the machine may wear more quickly than they should.

- Remove the remaining components and lay them out on the floor.
- If you have any questions about the steps in the installation process, please call Southworth Customer Service at 1-800-743-1000.

## Assembly

- Install the tower and carriage assembly. Remove the nuts and washers from the four studs on the tower mounting plate.
- Lift the tower and carriage assembly and position it above the motor and tower mounting plate.

**⚠ WARNING**

The tower and carriage assembly weighs about 120 lbs. To prevent back injury, get a helper to assist with this assembly. Bend your knees, and keep your back straight as you lift.

- Align the four holes in the tower base plate with the studs on the mounting plate. Lower the tower and carriage assembly onto the mounting plate.
- Install and tighten the washers and nuts.

**⚠ WARNING**

Do not use the machine without tightening the bolts that hold the tower and film carriage assembly. If you do not do this, the tower may fall when you try to raise the film carriage. You may be injured, or the machine may be damaged.

**⚠ CAUTION**

Do not move the machine once you have attached the tower. If you must move the machine, disassemble the tower first. If you strike the tower while moving the machine, it is very easy to damage the machine.

## Anchoring the Unit

Once the tower has been attached, the machine must be anchored before you use it. The machine has holes for 7 lag bolts. See Fig. 1.

**⚠ CAUTION**

Do not use the machine unless it has been firmly anchored to the floor. If you do not do this, the machine may move as it operates. This can create stresses, which may damage the machine.

## Electrical Connections

Plug the power cord directly into a 115V AC outlet. Do not use an extension cord. When possible, use a dedicated service to provide power to the machine. This eliminates voltage drops, which may cause the machine to work erratically. The power source should have a 15-amp fuse or circuit breaker.

## Testing

1. Press the footswitch. The turntable should begin to rotate in a clockwise direction.
2. Grip the handle on the film carriage. Raise and lower the carriage. It should travel up and down the tower with little resistance.

## OPERATING INSTRUCTIONS

Do not use this unit with a load greater than 2500 lbs. This includes the weight of the payload and the weight of the pallet. If you overload the machine, it may be damaged.

This machine is designed for light commercial duty. Do not use the unit to process more than 20 pallets per day. If you try to use the machine more often, or try to use the machine continuously, the machine may be damaged. The motor may overheat, and other parts may wear quickly.

Do not use the machine with a pallet which is larger than 50" x 50". If you try to use a larger pallet, a corner of the pallet may hit one of the fixed parts of the machine. This can cause the pallet or the load to shift. You may be injured, and the machine may be damaged.

Do not try to use this machine with damaged or broken pallets. Broken pallets may have boards or nails that hang down below the main part of the pallet. As the pallet is turned, these boards or nails may catch on the belt guard. See Fig. 1. This can cause the pallet to stop turning suddenly, and this can cause the load to shift. You may be injured, and the machine may be damaged. Boards or nails may extend up to 1/8 inch below the bottom of the pallet. If necessary, you can raise the bottom of the pallet by placing spacers on the turntable. Use pieces of 2" x 4" lumber, about 36" long. Don't use small blocks to support the pallets - these may not be stable when the load begins turning.

The power cord can be damaged or cut by sharp objects. Keep all sharp objects away from the power cord. Don't step

on the power cord or drop anything on it. If the power cord is damaged, you may be exposed to 120V AC electricity. Do not use the machine if the power cord is damaged in any way.

Never use this machine if it is wet or under water. This can create a serious electrical shock. Protect the unit from rain and moisture. The machine is not intended to be used in a washdown environment.

Do not drop the load on the turntable. If you do this while the turntable is moving, the load may shift. You may be injured, or the machine may be damaged. If you drop the load while the turntable is stopped, the machine may be damaged. Keep the area around machine clean. Do not allow any dirt, debris, spilled oil, or excess grease to collect. These materials may cause you to slip while the machine is operating, and you may be injured.

Stay clear of the turntable when it is moving. As the pallet turns, a part of the load may rotate around and hit you. Never operate the unit when anyone is standing on the turntable. The person on the turntable may be thrown off and injured.

Keep the film carriage in the latched (lower) position when the machine is unattended or not in use.

## Loading Film

1. Loosen the hand knob near the top of the film carriage. Remove the upper saddle core from the shaft in the center of the carriage.
2. Place the roll of film over the shaft. The new roll may be up to 20 inches wide. As you look down on the roll of film, the loose end of the film should be on the left. When you pull film off of the roll, the roll should turn in a clockwise direction.
3. Replace the upper saddle core. Tighten the hand knob to provide the desired film tension.

## Wrapping Film

1. Place a pallet on the turntable. The unit is designed with a low clearance so it can be loaded by a pallet jack. Place the center of the load over the center of the turntable.



Never operate the unit if the load is off-center. As the turntable moves, the load may shift, and you may be injured. This can also damage the machine.

**⚠ WARNING**

Do not drop the load on the turntable. If you do this while the turntable is moving, the load may shift. You may be injured, or the machine may be damaged. If you drop the load while the turntable is stopped, the machine may be damaged.

2. Walk halfway around the load and attach one end of the film to the side of the load.
3. Press the footswitch to start the turntable rotation. Some pallets tend to sag a bit at the corners. The corners may hit the sides of the belt cover. See Fig. 1. If the corners hit, stop the machine and place blocks under the pallet to raise it.

**⚠ WARNING**

Stay clear of the turntable while it is moving. As the pallet turns, a part of the load may rotate around and hit you. Never operate the unit when anyone is standing on the turntable. The person on the turntable may be thrown off and injured.

4. Grasp the handle on the film carriage. As the turntable turns, raise and lower the film carriage to wrap different parts of the load. The amount of overlap between pieces of film is determined by how fast you raise and lower the carriage.
5. The knob on top of the film carriage is used to adjust the film tension. If the film breaks or stretches, the tension is too high. Reduce the tension by turning the knob counterclockwise.

**⚠ WARNING**

If the load is very light and there is too much tension on the film, the load can be pulled off of the pallet. The load may be damaged, and you may be injured.

6. When the load has been wrapped, lower the film carriage. Be sure the latch is engaged to hold the carriage in position.
7. Cut the film. Attach the trailing edge of the film to the load.
8. Remove the pallet with the wrapped load.

## Stopping the Machine

1. To stop the machine, remove your foot from the footswitch.
2. When the machine is unattended or not in use, lower the film carriage into the latched position.

## Operation Notes

**⚠ DANGER**

The power cord can be damaged or cut by sharp objects. Keep all sharp objects away from the power cord. Don't step on the power cord or drop anything on it. If the power cord is damaged, you may be exposed to 120V AC electricity. Do not use the machine if the power cord is damaged in any way.

**⚠ DANGER**

Never use this machine if it is wet or under water. This can create a serious electrical shock. Protect the unit from rain and moisture. The machine is not intended to be used in a washdown environment.

**⚠ WARNING**

Never operate the unit if the load is off-center. The load may shift, and you may be injured. This can also damage the machine.

**⚠ WARNING**

Do not try to use this machine with damaged or broken pallets. Broken pallets may have boards or nails, which hang down below the main part of the pallet. As the pallet is turned, these boards or nails may catch on the belt guard. See Fig. 1. This can cause the pallet to stop turning suddenly, and this can cause the load to shift. You may be injured, and the machine may be damaged. Boards or nails may extend up to 1/8 inch below the bottom of the pallet. If necessary, you can raise the bottom of the pallet by placing spacers on the turntable. Use pieces of 2" x 4" lumber, about 36" long. Don't use small blocks to support the pallets - these may not be stable when the load begins turning.

**⚠ WARNING**

Do not use the machine with a pallet which is larger than 50" x 50". If you try to use a larger pallet, a corner of the pallet may hit one of the fixed parts of the machine. This can cause the pallet or the load to shift. You may be injured, and the machine may be damaged.

**⚠ WARNING**

Do not drop the load on the turntable. If you do this while the turntable is moving, the load may shift. You may be injured, or the machine may be damaged. If you drop the load while the turntable is stopped, the machine may be damaged.

**⚠ WARNING**

Keep the area around machine clean. Do not allow any dirt, debris, spilled oil, or excess grease to collect. These materials may cause you to slip while the machine is operating, and you may be injured.

**⚠ WARNING**

Stay clear of the turntable when it is moving. As the pallet turns, a part of the load may rotate around and hit you. Never operate the unit when anyone is standing on the turntable. The person on the turntable may be thrown off and injured.

**⚠ CAUTION**

Keep the film carriage in the latched (lower) position when the machine is unattended or not in use.

**⚠ CAUTION**

Do not use this unit with a load greater than 2500 lbs. This includes the weight of the payload and the weight of the pallet. If you overload the machine, it may be damaged.

**⚠ CAUTION**

This machine is designed for light commercial duty. Do not use the unit to process more than 20 pallets per day. If you try to use the machine more often, or try to use the machine continuously, the machine may be damaged. The motor may overheat, and other parts may wear quickly.

## Safety Labels

When it is shipped from the factory, the machine includes the following safety labels. Be sure all of these labels are in place. Never paint over the labels. Replacements are available from Southworth.

- A series of labels around the turntable indicating that workers should not stand on the turntable.
- A label on the belt guard: "Maximum capacity 2500 lbs."
- Two labels on the sides of the belt guard: "Warning - Machine must be lagged down to a flat surface."

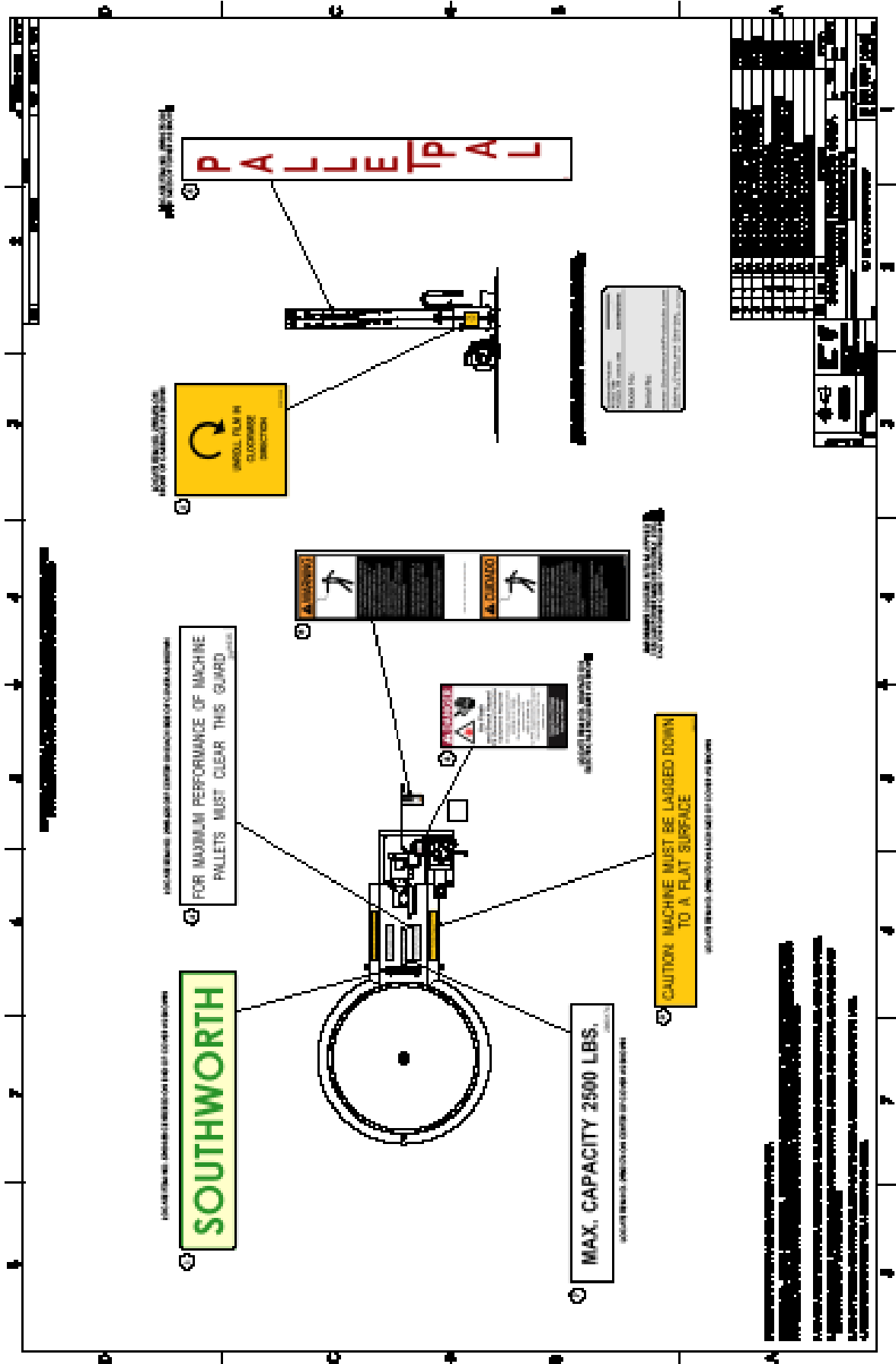

## Maintenance

### DANGER

This machine contains electrical parts which carry 120V AC. If you touch an exposed part while it is charged, you may be killed or injured. Do not work on the machine unless you are a trained electrician or electrical technician. Always disconnect the power before you service the machine. (Remember to do this if you lubricate the machine.)

### Routine Periodic Maintenance

#### After the first 100 hours of operation –

- Inspect the machine carefully. Tighten any loose nuts, screws, set screws, sprocket keys, etc. Do not change the oil in the gear drive.
- It is normal to see some wear on the plates under the turntable. After a short “break-in” period, this wear should be reduced.

#### At the start of each shift –

- Make a general walk-around inspection. Remove any dirt and debris from the machine.
- Check for loose or damaged components and wiring.
- Check the condition of the power cord. Don't use the unit if the power cord is damaged.

#### Every month –

- Remove the belt cover and check the condition of the belt. The driving surfaces of the belt should be smooth, but not hard and shiny or cracked. If the belt is worn or damaged, replace it.
- Check the belt tension. Press on one section of the belt in the middle of its run. If you can deflect the belt more than 1/2 inch, tighten the belt.

#### Once a year –

Change the oil in the reducer. Use SAE 90 gear oil.

### Adjusting the Belt Tension

1. Unplug the machine.
2. Remove the two sheet metal screws that hold the belt cover in place.
3. Loosen the four bolts that hold the motor mounting bracket.
4. The belt adjustment mechanism includes two adjusting bolts with locking nuts. Back off the locking nuts. Turn the adjusting bolts until you have the correct belt tension.

Press on one section of belt in the middle of its run. You should be able to deflect the belt about 1/4 inch. Adjust both bolts by the same amount.

5. Re-tighten the locking nuts.
6. Replace the belt cover and re-tighten the sheet metal screws.
7. Plug in the machine.

### Removing the Turntable

1. Unplug the machine.
2. Remove the belt guard. Use the two adjusting bolts to release the tension on the drive belt. Remove the belt from the drive pulley under the motor.
3. Use a pair of snap-ring pliers to remove the snap ring in the center of the turntable.
4. Use a lever to lift one edge of the turntable. Start by lifting the edge that is nearest the belt guard.

### WARNING

The turntable is very heavy. You will need at least three people to lift this part safely. Be sure to wear heavy gloves when performing this job.

5. Lift the edge of the turntable just a bit so that you can reach the belt. Pull the belt away from the turntable.

### CAUTION

Be careful to keep the belt away from the grease. If the belt does touch the grease, you must remove the grease before you re-assemble the machine. Use the smallest possible amount of spray degreaser. Degreaser tends to dry out the rubber material in the belt, so use it sparingly.

6. Once the belt is free, you can lift the turntable away from the machine.
7. If necessary, you can now remove the carrier plate. The steel balls used in the machine will remain in the lower part of the machine. Don't do this unless you want to degrease the bearings - it can be time-consuming to reassemble this part of the machine.
8. There are 72 balls, 5/8 inch in diameter, in the carrier plate. These are standard chrome-plated steel balls.
9. If you have removed the carrier plate, put it back in position. Place each of the balls in one of the bearings. Be sure that every bearing has a ball. The machine uses the large number of bearings to spread out the weight of the load. If some of the balls are missing, the machine may not work properly, and may wear more quickly.



- To reassemble the machine, reverse the remaining steps listed above.

### Inspecting and Lubricating the Turntable

- Unplug the machine.
- Remove the belt guard and release the tension on the drive belt. Remove the belt from the drive pulley under the motor.
- Remove the turntable as described in the last section.
- Lift out the carrier plate. Collect the 72 steel balls.
- Degrease the carrier plate and the steel balls.
- Inspect the steel balls for signs of wear. Check several balls for discoloration or breakdown of the chrome layer.
- Set the carrier plate back in position. Place each of the balls in one of the bearings. Be sure that every bearing has a ball. The machine uses the large number of bearings to spread out the weight of the load. If some of the balls are missing, the machine may not work properly, and may wear more quickly.
- Place a bit of grease inside the opening of each bearing.
- Work some grease into the bearing at the center of the turntable. The bearings for the V-belt idler rolls are sealed and do not need lubrication.
- To reassemble the machine, reverse the remaining steps listed above. Guide the belt over the idler wheels on either side of the belt guard. Be careful not to let the drive belt touch the grease.

#### CAUTION

Be careful to keep the belt away from the grease. If the belt does touch the grease, you must remove the grease before you reassemble the machine. Use the smallest possible amount of

spray degreaser. Degreaser tends to dry out the rubber material in the belt, so use it sparingly.

### Changing the Drive Belt

Change the belt if it is cracked or dried out, or if the sides of the belt become very shiny. The belt is an A-size V-belt, 183 inches long.

- Unplug the machine.
- Remove the belt guard and release the tension on the drive belt. Remove the old belt from the drive pulley under the motor.
- Remove the turntable as described earlier. Leave the carrier plate in position - do not remove it.
- Replace the turntable, running the new belt around the base of the part. Be careful not to let the new belt touch the grease here.

#### CAUTION

Be careful to keep the belt away from the grease. If the belt does touch the grease, you must remove the grease before you reassemble the machine. Use the smallest possible amount of spray degreaser. Degreaser tends to dry out the rubber material in the belt, so use it sparingly.

- Guide the belt around the two idler pulleys at the end of the belt guard.
- Guide the belt around the drive pulley under the motor. Tighten the two bolts that set the belt tension. The free play in the center of the belt's run should be about 1/4 inch.
- Replace the belt guard and plug in the machine.

## Troubleshooting Check List

Problem	Possible Cause	Check This
Turntable does not start, motor is dead.	No power to motor.	Check power source, power cord, start switch.
	Drive belt broken or slipping.	Remove belt cover. Check belt condition. Check for correct tension.
Turntable starts slowly.	Drive belt is loose.	Check belt tension and adjust if necessary.
	Drive belt is worn.	Check for shiny surface and cracks. Replace if necessary.
	Grease on drive belt.	Remove belt guard and inspect belt. If belt is contaminated, remove turntable. Degrease turntable and belt.
Excessive "rumble" when unit operates	Wear or lack of lubrication to bearings under turntable.	Remove turntable, inspect, lubricate.
Drive belt wears quickly.	Mounting surface is not flat.	Check for flatness using a level.
Drive motor overheats.	Exceeding duty cycle.	Unit is designed for 20 pallets per day maximum.
	Unit is overloaded.	Unit is designed for 2500 lb. load including the weight of pallet.



## ORDERING REPLACEMENT PARTS

Southworth has carefully chosen the components in your lift to be the best available for the purpose. Replacement parts should be identical to the original equipment. Southworth will not be responsible for equipment failures resulting from the use of incorrect replacement parts or from unauthorized modifications of the machine.

Southworth will gladly supply you with replacement parts for your Southworth lift. With your order, please include the model number and the serial number of the lift. You may find these numbers on the nameplate, which is located on the crossbar at the base of the cylinder(s). When you are ordering parts for a cylinder, also include the cylinder number. This is stamped on the base of the cylinder housing.

To order replacement parts, please call the Parts Department at (207) 878-0700 or (800)743-1000. Parts are shipped subject to the following terms:

- FOB factory
- Returns only with the approval of our parts department
- Payment net 30 days (except parts covered by warranty)
- Freight collect (except parts covered by warranty)
- The warranty for repair parts is 30 days from date of shipment

Parts replaced under warranty are on a “charge-credit” basis. We will invoice you when we ship the replacement part, then credit you when you return the worn or damaged part, and we verify that it is covered by our warranty. Labor is not covered under warranty for Parts orders.

SOUTHWORTH PRODUCTS CORP  
Parts Department  
Telephone: (207) 878-0700  
(800) 743-1000  
Fax: (207) 797-4734  
[repairparts@southworthproducts.com](mailto:repairparts@southworthproducts.com)

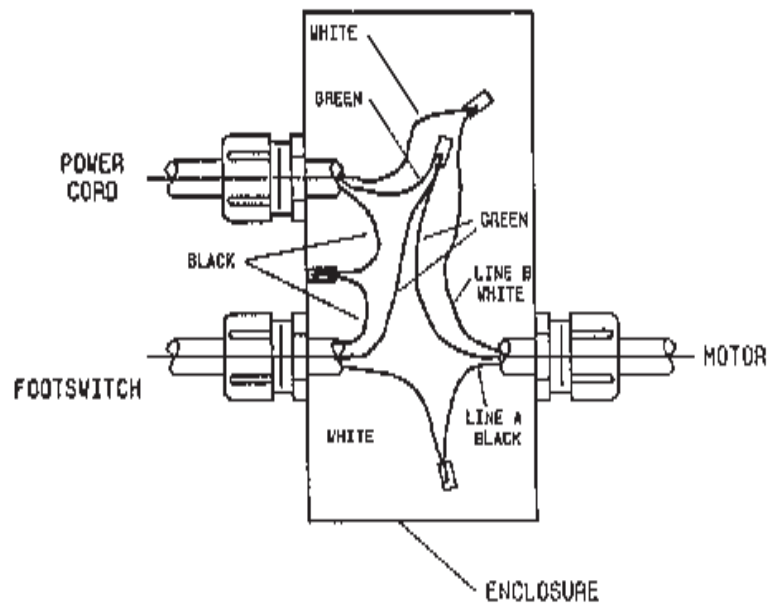

NOTE: ENTRY LOCATIONS MAY DIFFER FROM THOSE SHOWN.  
GROUND CONNECTIONS, ALTHOUGH NOT SHOWN, ARE REQUIRED.

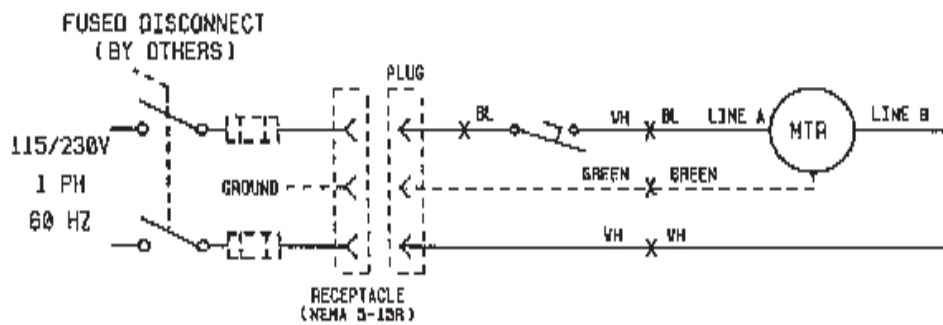

Fig. 3 Wiring Diagram

**NOTES**

---

---

---

---

---

---

---

---

---

---

---

---

---

---

---

---

---

---

---

---

---

---

---

---

---

---

---

---

---

---

# 2 YEAR WARRANTY

Southworth Products Corp warrants this product to be free from defects in material or workmanship for a period of **two years** of single shift usage from date of shipment, providing claim is made in writing within that time period. This warranty shall not cover modified designs for special applications, failure or defective operation caused by misuse, misapplication, negligence or accident, exceeding recommended capacities, failure to perform required maintenance or altering or repairing, unless alteration is authorized by Southworth Products Corp. Except as set forth herein, there are no other warranties, express or implied, including the warranties of merchantability and fitness for a particular purpose, all of which are hereby excluded.

Southworth Products Corp makes no warranty or representation with respect to the compliance of any product with state or local safety or product standard codes, and any failure to comply with such codes shall not be considered a defect of material or workmanship under this warranty. Southworth Products Corp shall not be liable for any direct or consequential damages arising out of such noncompliance.

Southworth Products Corp's obligation under this warranty is limited to the replacement or repair of defective components at its factory or another location at Southworth Products Corp's discretion. The Southworth Warranty is for product sold with in North America. For products shipped outside of North America the warranty will be for replacement of defective parts only. Labor is not included. This is buyer's sole remedy. Except as stated herein, Southworth Products Corp will not be liable for any loss, injury or damage to persons or property, nor for direct, indirect, or consequential damage of any kind, resulting from failure or defective operation of said product.

This warranty may be altered only in writing by Southworth Products Corp, Portland, Maine.

**SOUTHWORTH**

SOUTHWORTH PRODUCTS CORP  
P.O. Box 1380, Portland, ME 04104-1380  
Telephone: (800) 743-1000 • (207) 878-0700  
Fax: (207) 797-4734  
[www.SouthworthProducts.com](http://www.SouthworthProducts.com)